

TYPES SN54LS68, SN54LS69, SN74LS68, SN74LS69 DUAL 4-BIT DECADE OR BINARY COUNTERS

REVISED DECEMBER 1983

- Heavy Duty Outputs I_{OL} Rated at 8mA/16 mA
- Counter One of Either 'LS68 or 'LS69 Has Individual Clicks for the A Flip-Flop
- Direct Clear for Each 4-Bit Counter
- Guaranteed Maximum Count Frequency is 50 MHz for 'LS69 and 40 MHz for 'LS68

description

Each of the 'LS68 and 'LS69 circuits contain two four-bit counters. The 'LS68 is a dual decade counter, while the 'LS69 is a dual binary counter. Counter number one of both the 'LS68 and 'LS69 has two clock pins. Clock 1 is for the A flip-flop, while clock 2 is for the B, C, D flip-flops. Counter one of the 'LS68 can perform bi-quinary counting. All $1Q_A$ outputs are rated with sufficient I_{OL} to drive clock 2 while maintaining a full fan-out.

All clocks trigger on the high-to-low transition of the clock pulse. All counters have direct overriding clear pins which, when low, reset Q_A , Q_B , Q_C , and Q_D low regardless of the state of the clock.

The SN54LS68 and SN54LS69 circuits are characterized for operation over the full military temperature range of -55°C to 125°C . The SN74LS68 and SN74LS69 circuits are characterized for operation from 0°C to 70°C

SN54LS68, SN54LS69 ... J PACKAGE
SN74LS68, SN74LS69 ... D, J OR N PACKAGE
(TOP VIEW)

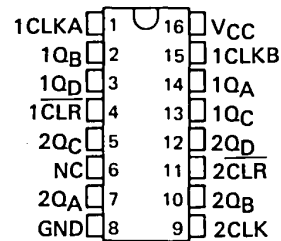

SN54LS68, SN54LS69 ... FK PACKAGE
SN74LS68, SN74LS69 ... FN PACKAGE
(TOP VIEW)

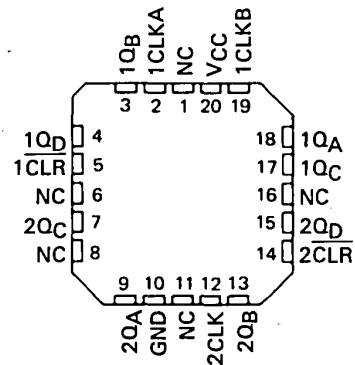

NC - No internal connection

PRODUCTION DATA
This document contains information current as of publication date. Products conform to specifications per the terms of Texas Instruments standard warranty. Production processing does not necessarily include testing of all parameters.

TEXAS
INSTRUMENTS

POST OFFICE BOX 225012 • DALLAS, TEXAS 75265

3-261

TTL DEVICES

3

TYPES SN54LS68, SN54LS69, SN74LS68, SN74LS69 DUAL 4-BIT DECADE OR BINARY COUNTERS

count sequence tables

'LS68 DECADE COUNTER BCD COUNT SEQUENCE

(See Note 1)

Applies to Counters 1 & 2

COUNT	OUTPUT			
	Q _D	Q _C	Q _B	Q _A
0	L	L	L	L
1	L	L	L	H
2	L	L	H	L
3	L	L	H	H
4	L	H	L	L
5	L	H	L	H
6	L	H	H	L
7	L	H	H	H
8	H	L	L	L
9	H	L	L	H

'LS68 DECADE COUNTER BI-QUINARY SEQUENCE

(See Note 2)

Applies to Counter 1 only

COUNT	OUTPUT			
	Q _A	Q _D	Q _C	Q _B
0	L	L	L	L
1	L	L	L	H
2	L	L	H	L
3	L	L	H	H
4	L	H	L	L
5	H	L	L	L
6	H	L	L	H
7	H	L	H	L
8	H	L	H	H
9	H	H	L	L

'LS69 BINARY COUNTER BCD COUNT SEQUENCE

(See Note 3)

Applies to Counters 1 & 2

COUNT	OUTPUT			
	Q _D	Q _C	Q _B	Q _A
0	L	L	L	L
1	L	L	L	H
2	L	L	H	L
3	L	L	H	H
4	L	H	L	L
5	L	H	L	H
6	L	H	H	L
7	L	H	H	H
8	H	L	L	L
9	H	L	L	H
10	H	L	H	L
11	H	L	H	H
12	H	H	L	L
13	H	H	L	H
14	H	H	H	L
15	H	H	H	H

- NOTES: 1. Output 1Q_A is connected to 1CLK2 for BCD count.
 2. Output 1Q_A is connected to 1CLK1 for bi-quinary count.
 3. Output 1Q_A is connected to 1CLK2 for binary count.

3

schematics of inputs and outputs

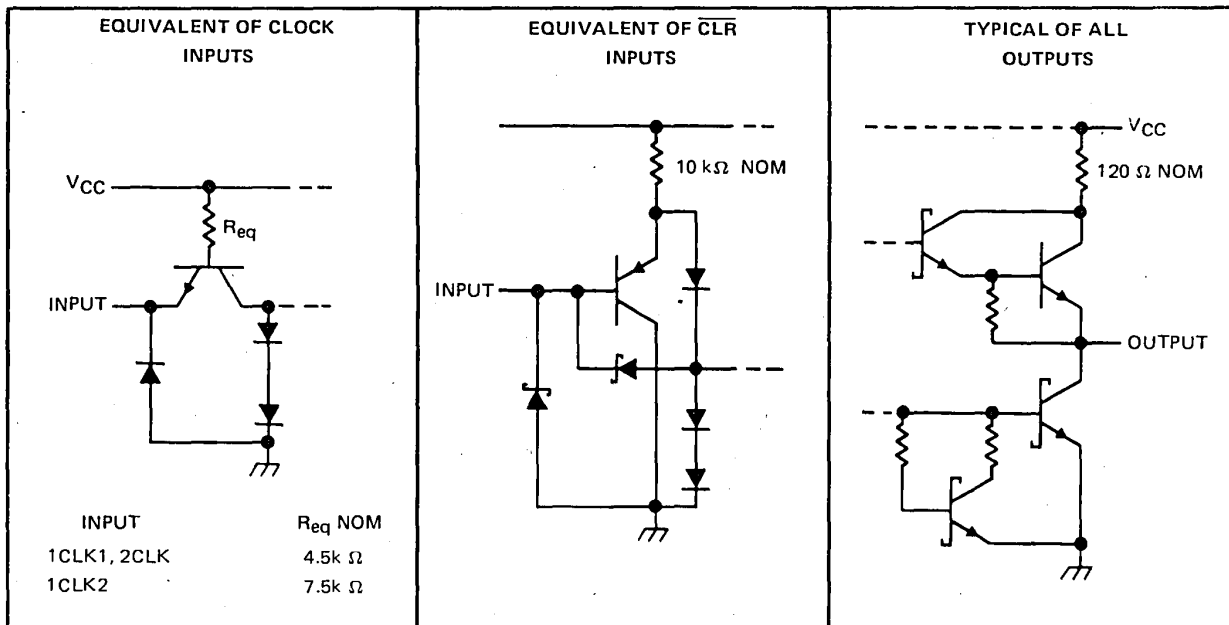

TTL DEVICES

TYPES SN54LS68, SN54LS69, SN74LS68, SN74LS69
 DUAL 4-BIT DECADE OR BINARY COUNTERS

logic diagrams

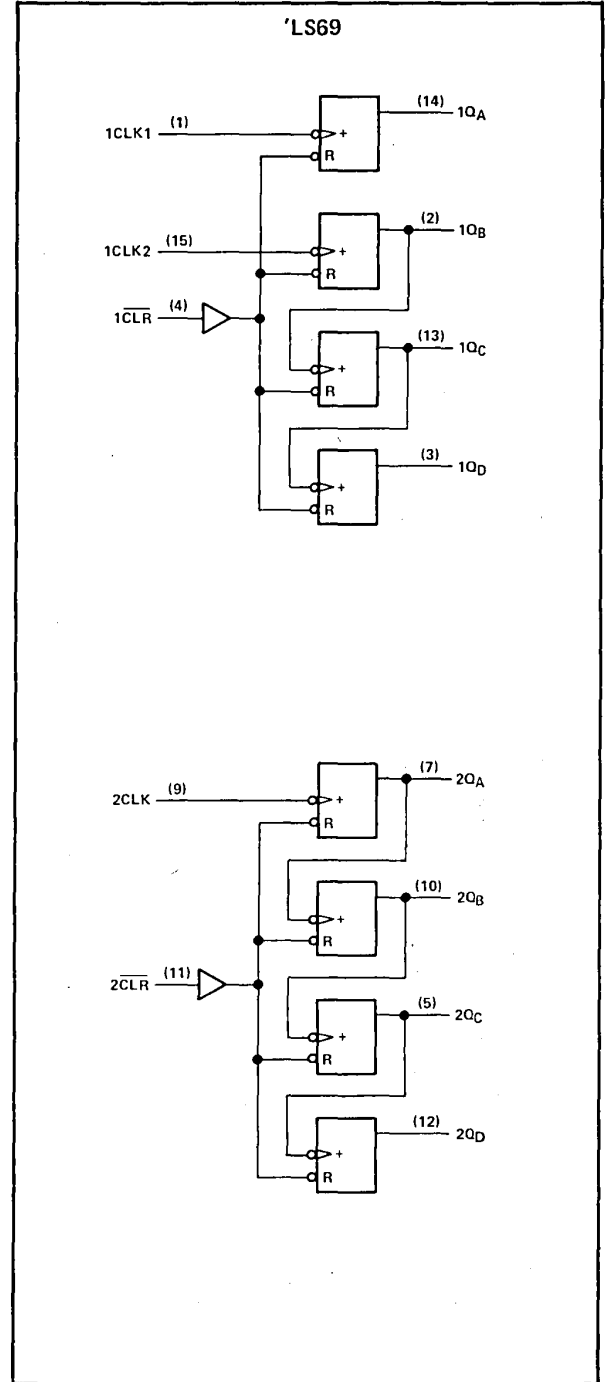
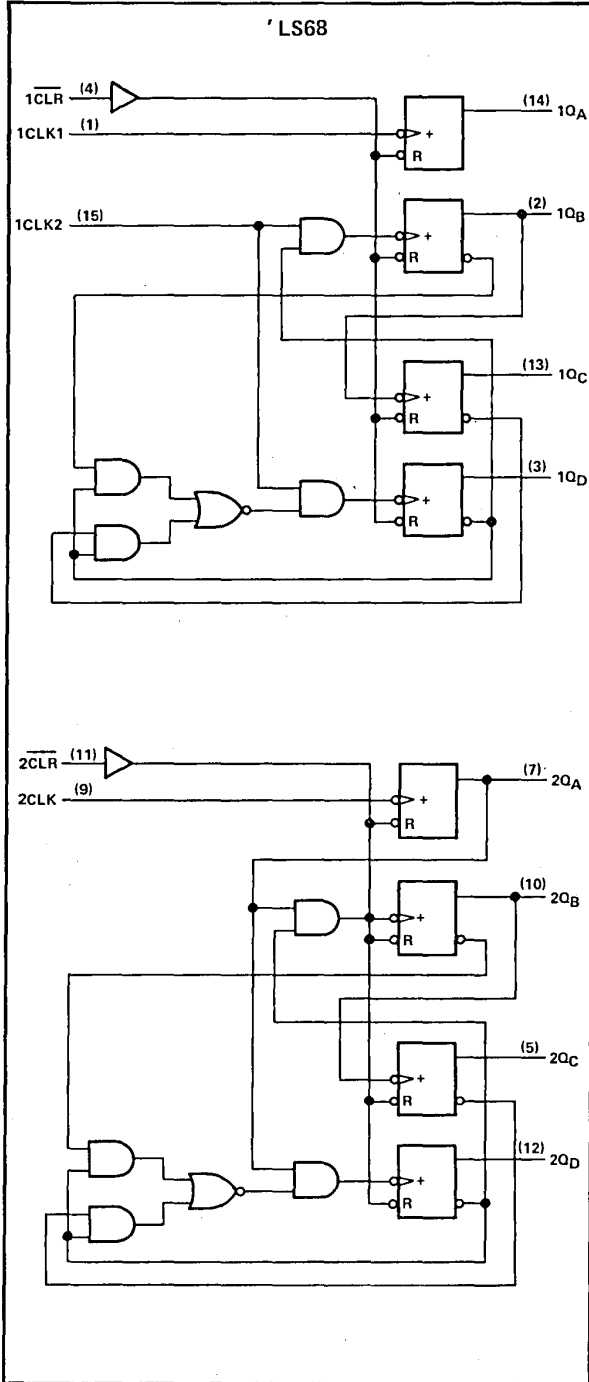

Pin numbers shown on logic notation are for D, J or N packages.

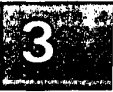

TTL DEVICES

TYPES SN54LS68, SN54LS69, SN74LS68, SN74LS69

DUAL 4-BIT DECADE OR BINARY COUNTERS

absolute maximum ratings over operating free-air temperature range (unless otherwise noted)

Supply voltage, V_{CC} (see Note 4)	7 V
Input voltage: Clear inputs	7 V
Clock inputs	5.5 V
Operating free-air temperature range: SN54LS'	-55°C to 125°C
SN74LS'	0°C to 70°C
Storage temperature range	-65°C to 150°C

NOTE 4: Voltage values are with respect to network ground terminal.

recommended operating conditions

		SN54LS'			SN74LS'			UNIT
		MIN	NOM	MAX	MIN	NOM	MAX	
V_{CC}	Supply voltage	4.5	5	5.5	4.75	5	5.25	V
V_{IH}	High-level input voltage	2			2			V
V_{IL}	Low-level input voltage	0.7			0.8			V
I_{OH}	High-level output current	-1			-1			mA
I_{OL}	Low-level output current	8			16			mA
f_{max}	Clock frequency	1CLK1	0	50	0	50	MHz	
		1CLK2	'LS68	0	20	0		20
			'LS69	0	25	0		25
		2CLK	'LS68	0	40	0		40
'LS69	0		50	0	50			
t_w	Pulse width	1CLK1	10		10	ns		
		1CLK2	'LS68	25	25			
			'LS69	20	20			
		2CLK	'LS68	13	13			
			'LS69	10	10			
CLEAR	15	15						
t_{su}	Clear inactive-state set-up time	25		25		ns		
T_A	Operating free-air temperature	-55	125	0	70	°C		

3

TTL DEVICES

TYPES SN54LS68, SN54LS69, SN74LS68, SN74LS69 DUAL 4-BIT DECADE OR BINARY COUNTERS

electrical characteristics over recommended operating free-air temperature range (unless otherwise noted)

PARAMETER	TEST CONDITIONS†	SN54LS'			SN74LS'			UNIT
		MIN	TYP‡	MAX	MIN	TYP‡	MAX	
V _{IK}	V _{CC} = MIN, I _I = -18 mA	-1.5			-1.5			V
V _{OH}	V _{CC} = MIN, V _{IH} = 2 V, V _{IL} = MAX, I _{OH} = -1 mA	2.5	3.4		2.7	3.4		V
V _{OL}	V _{CC} = MIN, V _{IH} = 2 V, V _{IL} = MAX, I _{OL} = 8 mA	0.25 0.4			0.25 0.4			V
		I _{OL} = 16 mA			0.35 0.5			
I _I	CLK	V _{CC} = MAX, V _I = 5.5 V			0.1 0.1			mA
	CLR	V _{CC} = MAX, V _I = 7 V			0.1 0.1			
I _{IH}	CLK	V _{CC} = MAX, V _I = 2.7 V			40 40			μA
	CLR	V _{CC} = MAX, V _I = 2.7 V			20 20			
I _{IL}	1CLK1, 2CLK	V _{CC} = MAX, V _I = 0.4 V			-2 -2			mA
	1CLK2	V _{CC} = MAX, V _I = 0.4 V			-1.2 -1.2			
	CLR	V _{CC} = MAX, V _I = 0.4 V			-0.2 -0.2			
I _{OS} §	V _{CC} = MAX, V _O = 0 V	-20	-100		-20	-100		mA
I _{CC}	V _{CC} = MAX, see Note 5	36 54			36 54			mA

† For conditions shown as MIN or MAX, use the appropriate value specified under recommended operating conditions.

‡ All typical values are at V_{CC} = 5 V, T_A = 25°C.

§ Not more than one output should be shorted at a time, and duration of the short-circuit should not exceed one second.

NOTE 5: I_{CC} is measured with all inputs grounded and all outputs open.

switching characteristics, V_{CC} = 5 V, T_A = 25°C (see note 6)

PARAMETER	FROM (INPUT)	TO (OUTPUT)	TEST CONDITIONS	'LS68			'LS69			UNIT
				MIN	TYP	MAX	MIN	TYP	MAX	
f _{max}	1CLK1	1Q _A	R _L = 1 kΩ, C _L = 30 pF	50	70		50	70		MHz
f _{max}		1Q _B , 1Q _C , 1Q _D		20	30		25	35		MHz
f _{max}		2Q _A , 2Q _B , 2Q _C , 2Q _D		40	60		50	70		MHz
t _{PLH}	1CLK1	1Q _A		7	11		7	11		ns
t _{PHL}				14	21		14	21		
t _{PLH}	1CLK2	1Q _B		8	12		7	11		ns
t _{PHL}				12	18		14	21		
t _{PLH}		1Q _C		15	23		16	24		
t _{PHL}				21	32		21	32		
t _{PLH}	1CLK2	1Q _D		8	12		25	38		ns
t _{PHL}				13	20		30	45		
t _{PLH}		2Q _A		7	11		7	11		
t _{PHL}				14	21		14	21		
t _{PLH}	2CLK	2Q _B		16	24		14	21		ns
t _{PHL}				19	29		19	29		
t _{PLH}		2Q _C	23	35		23	35			
t _{PHL}			27	40		27	40			
t _{PLH}	2CLK	2Q _D	16	24		32	48		ns	
t _{PHL}			19	29		36	54			
t _{PHL}	Any CLR	Any Q	20	30		20	30		ns	

NOTE 6: See General Information Section for load circuits and voltage waveforms.



TTL DEVICES

TEXAS
INSTRUMENTS

POST OFFICE BOX 225012 • DALLAS, TEXAS 75265

3-265