

# TYPES SN54LS682 THRU SN54LS689, SN74LS682 THRU SN74LS689 8-BIT MAGNITUDE/IDENTITY COMPARATORS

D2617, JANUARY 1981—REVISED DECEMBER 1983

- Compares Two 8-Bit Words
- Choice of Totem-Pole or Open-Collector Outputs
- Hysteresis at P and Q Inputs
- 'LS682 and 'LS683 have 20-kΩ Pullup Resistors on the Q Inputs
- 'LS686 and 'LS687 . . . New JT and NT 24-Pin, 3000-Mil Packages

TYPE	$\overline{P} = \overline{Q}$	$P > Q$	OUTPUT ENABLE	OUTPUT CONFIGURATION	20-kΩ PULLUP
'LS682	yes	yes	no	totem-pole	yes
'LS683	yes	yes	no	open-collector	yes
'LS684	yes	yes	no	totem-pole	no
'LS685	yes	yes	no	open-collector	no
'LS686	yes	yes	yes	totem-pole	no
'LS687	yes	yes	yes	open-collector	no
'LS688	yes	no	yes	totem-pole	no
'LS689	yes	no	yes	open-collector	no

SN54LS682 THRU SN54LS685 . . . J PACKAGE  
SN74LS682 THRU SN74LS685 . . . DW, J OR N PACKAGE  
(TOP VIEW)

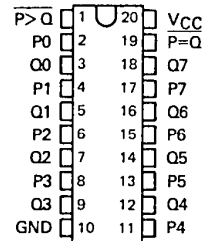

SN54LS682 THRU SN54LS685 . . . FK PACKAGE  
SN74LS682 THRU SN74LS685 . . . FN PACKAGE  
(TOP VIEW)

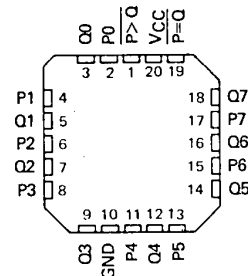

SN54LS686, SN54LS687 . . . JT PACKAGE  
SN74LS686, SN74LS687 . . . DW, JT OR NT PACKAGE  
(TOP VIEW)

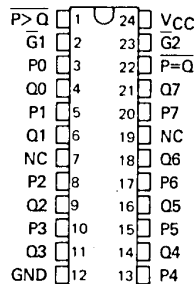

SN54LS686, SN54LS687 . . . FK PACKAGE  
SN74LS686, SN74LS687 . . . FN PACKAGE  
(TOP VIEW)

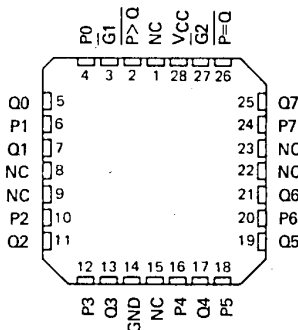

NC - No internal connection

SN54LS688, SN54LS689 . . . J PACKAGE  
SN74LS688, SN74LS689 . . . DW, J OR N PACKAGE  
(TOP VIEW)

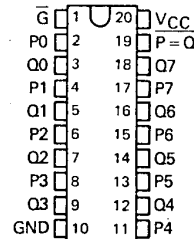

SN54LS688, SN54LS689 . . . FK PACKAGE  
SN74LS688, SN74LS689 . . . FN PACKAGE  
(TOP VIEW)

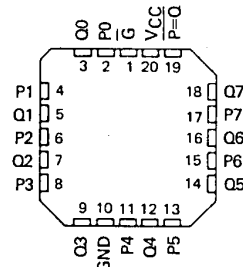

TTL DEVICES

**PRODUCTION DATA**  
This document contains information current as of publication date. Products conform to specifications per the terms of Texas Instruments standard warranty. Production processing does not necessarily include testing of all parameters.

**TEXAS  
INSTRUMENTS**

POST OFFICE BOX 225012 • DALLAS, TEXAS 75265

3-1295

# TYPES SN54LS682 THRU SN54LS689, SN74LS682 THRU SN74LS689 8-BIT MAGNITUDE/IDENTITY COMPARATORS

## description

These magnitude comparators perform comparisons of two eight-bit binary or BCD words. All types provide  $\overline{P = Q}$  outputs and the 'LS682 thru 'LS687 provide  $\overline{P > Q}$  outputs as well. The 'LS682, 'LS684, 'LS686, and 'LS688 have totem-pole outputs, while the 'LS683, 'LS685, 'LS687, and 'LS689 have open-collector outputs. The 'LS682 and 'LS683 feature 20-k $\Omega$  pullup termination resistors on the Q inputs for analog or switch data.

FUNCTION TABLE

INPUTS			OUTPUTS	
DATA	ENABLES		$\overline{P = Q}$	$\overline{P > Q}$
P, Q	$\overline{G_1}, \overline{G_1}$	$\overline{G_2}$		
P = Q	L	X	L	H
P > Q	X	L	H	L
P < Q	X	X	H	H
P = Q	H	X	H	H
P > Q	X	H	H	H
X	H	H	H	H

- NOTES: 1. The last three lines of the function table applies only to the devices having enable inputs, i.e., 'LS686 thru 'LS689.  
2. The P < Q function can be generated by applying the P = Q and P > Q outputs to a 2-input NAND gate.  
3. For 'LS686, 'LS687 G1 enables P = Q, and G2 enables P > Q.

## logic symbols

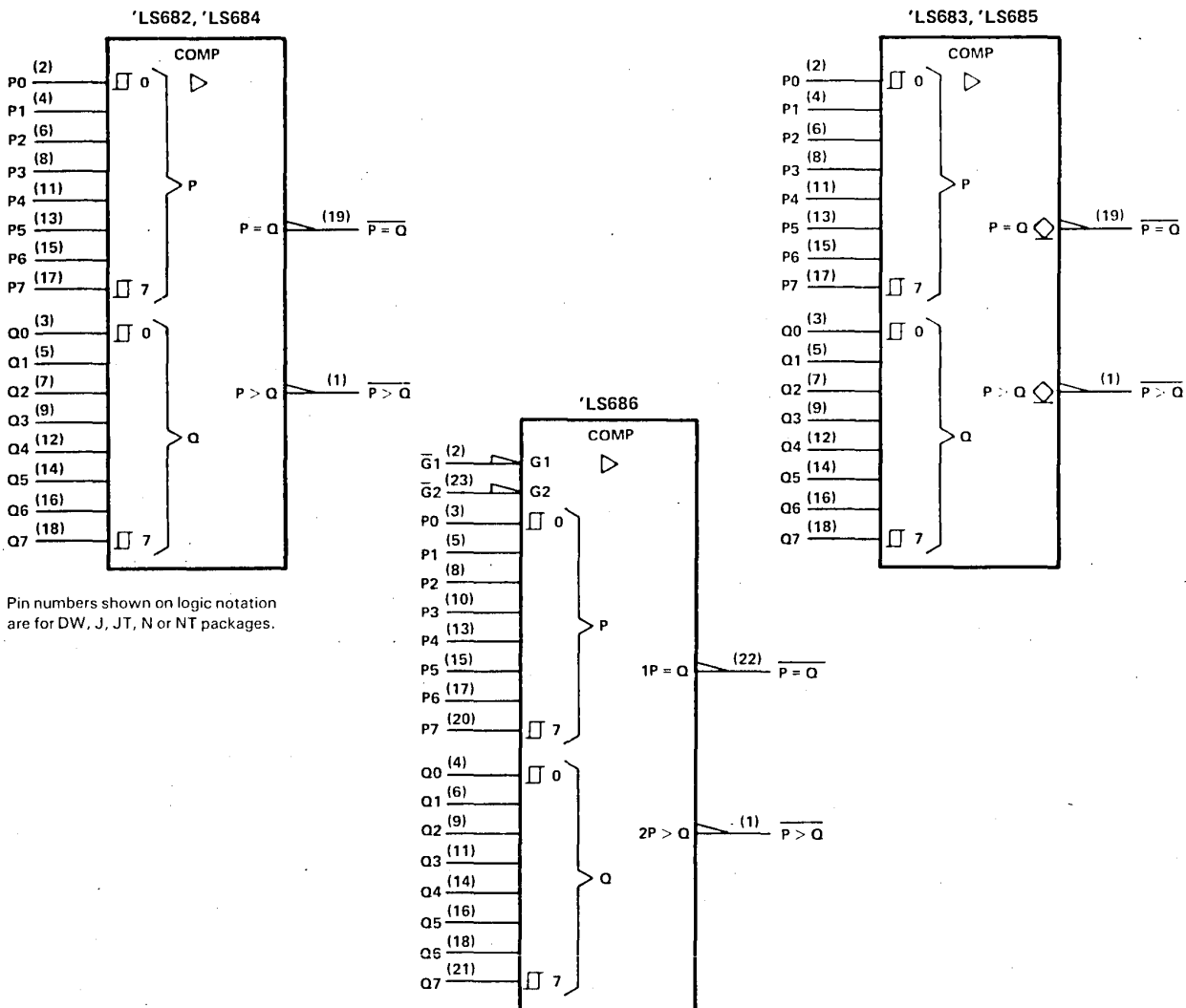

3

TTL DEVICES

# TYPES SN54LS682 THRU SN54LS689, SN74LS682 THRU SN74LS689 8-BIT MAGNITUDE/IDENTITY COMPARATORS

## logic symbols (continued)

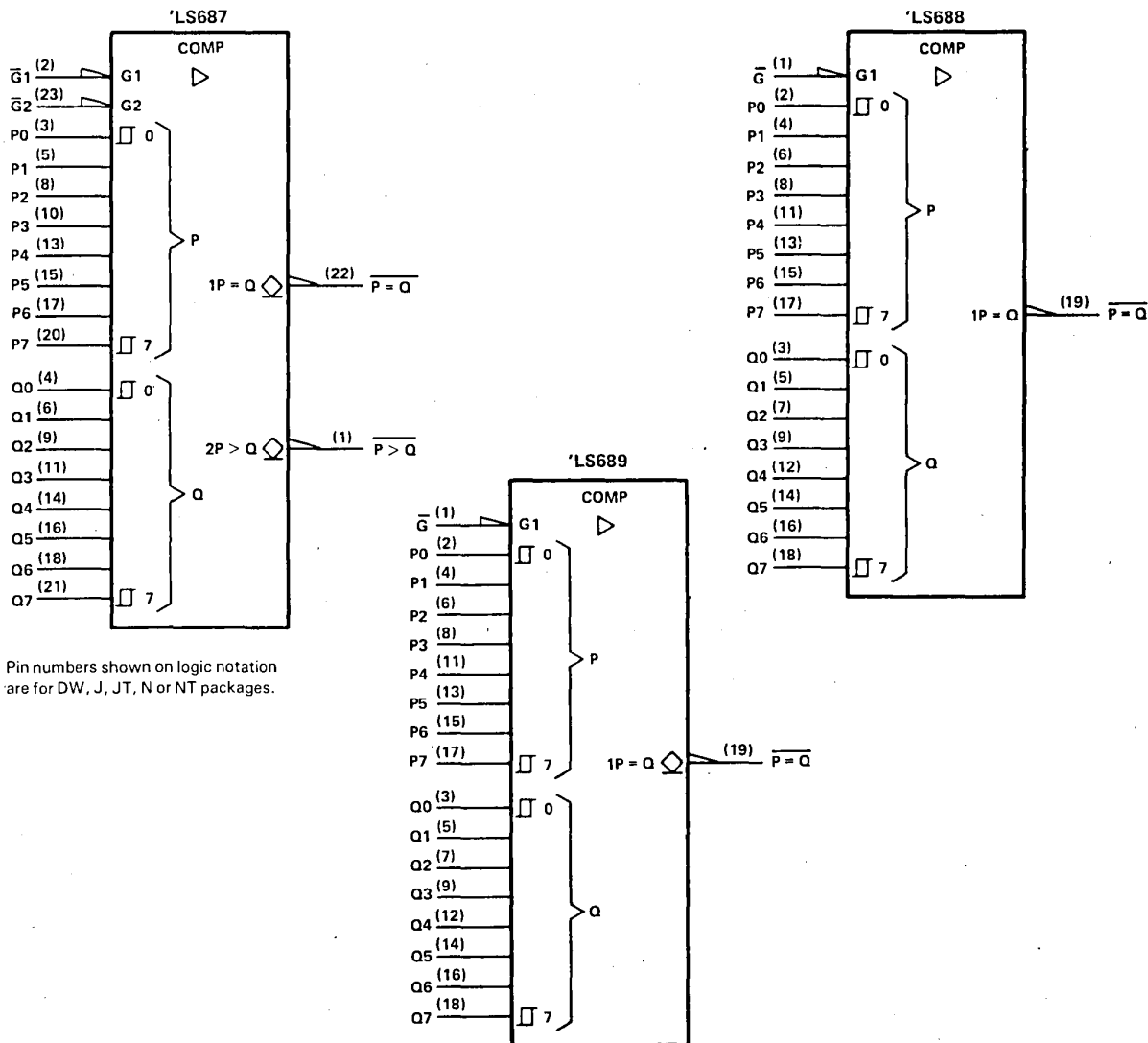

## schematics of inputs and outputs

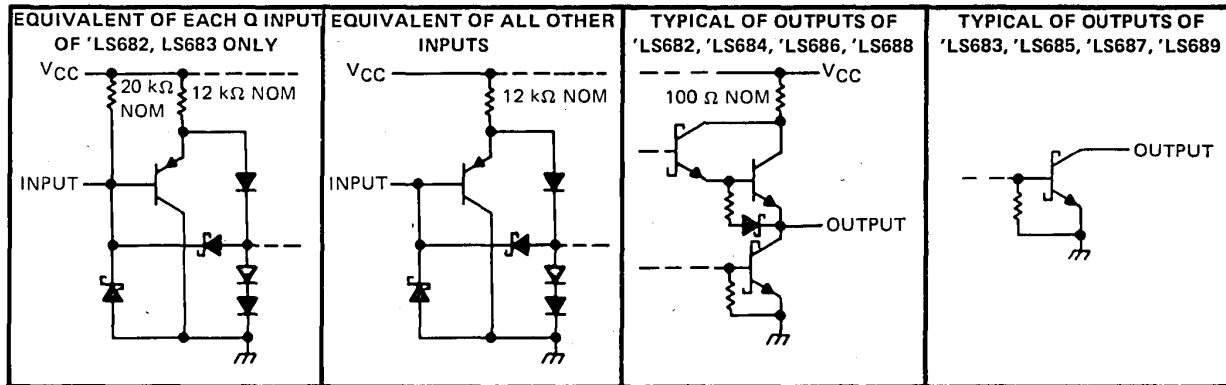

TYPES SN54LS682 THRU SN54LS685  
 SN74LS682 THRU SN74LS685  
 8-BIT MAGNITUDE/IDENTITY COMPARATORS

'LS682 thru 'LS685 logic diagram (positive logic)

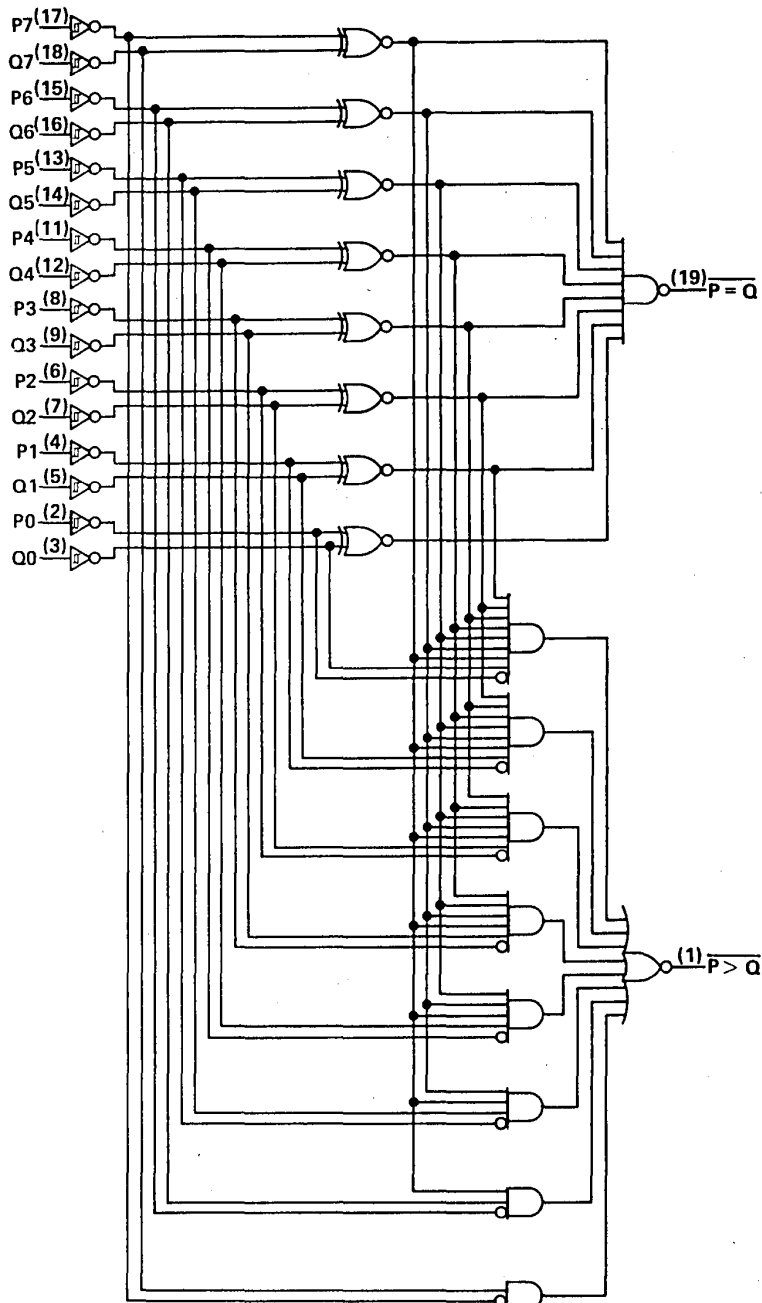

Pin numbers shown on logic notation are for DW, J or N packages

3

TTL DEVICES

TYPES SN54LS686, SN54LS687  
 SN74LS686, SN74LS687  
 8-BIT MAGNITUDE/IDENTITY COMPARATORS

'LS686, 'LS687 logic diagram (positive logic)

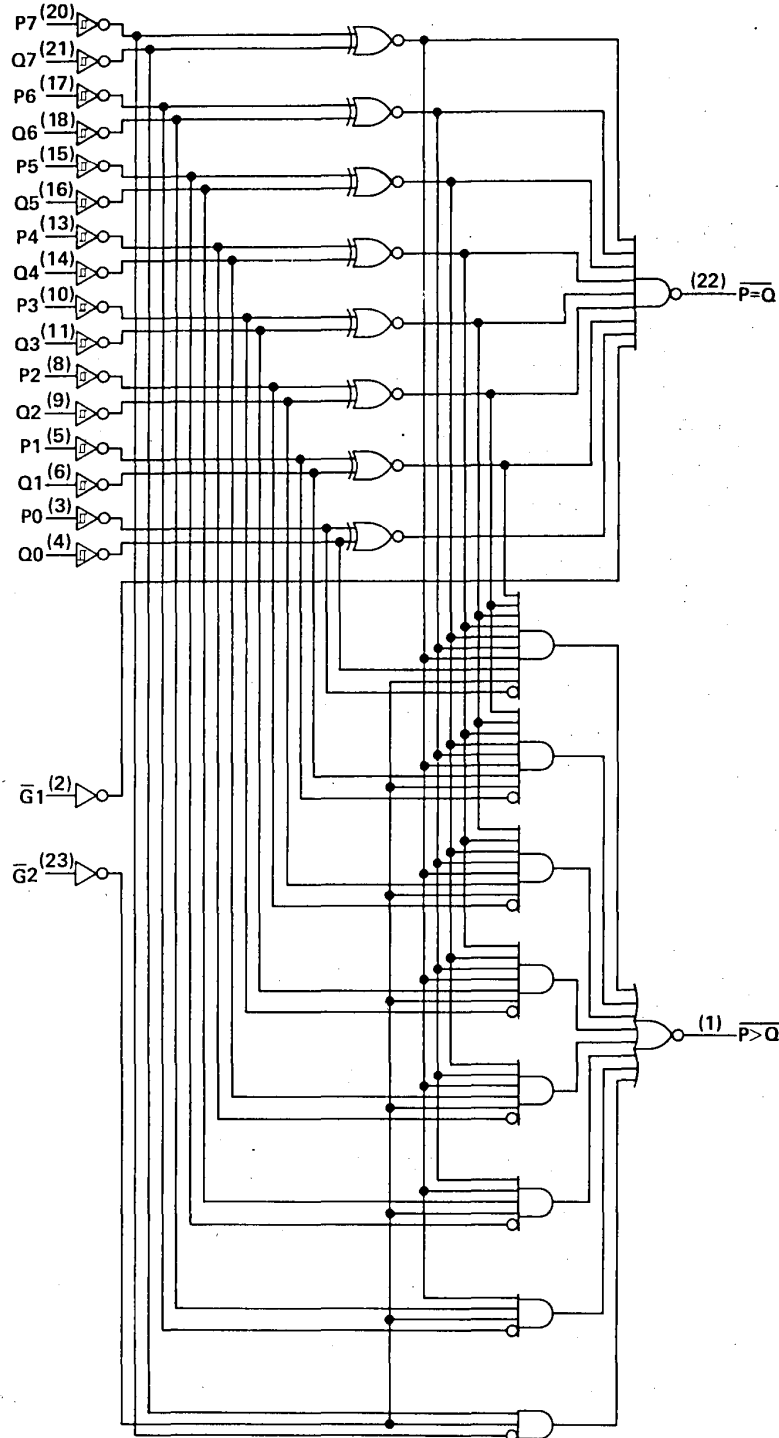

Pin numbers shown on logic notation are for DW, JT, or NT packages.



**TYPES SN54LS682, SN54LS684, SN54LS686, SN54LS688,  
SN74LS682, SN74LS684, SN74LS686, SN74LS688  
8-BIT MAGNITUDE/IDENTITY COMPARATORS WITH TOTEM-POLE OUTPUTS**

'LS682, 'LS684, 'LS686, 'LS688

recommended operating conditions

	SN54LS'			SN74LS'			UNIT
	MIN	NOM	MAX	MIN	NOM	MAX	
Supply voltage, $V_{CC}$	4.5	5	5.5	4.75	5	5.25	V
High-level output current, $I_{OH}$			-400			-400	$\mu$ A
Low-level output current, $I_{OL}$			12			24	mA
Operating free-air temperature, $T_A$	-55		125	0		70	$^{\circ}$ C

electrical characteristics over recommended operating free-air temperature range (unless otherwise noted)

PARAMETER		TEST CONDITIONS†	SN54LS'			SN74LS'			UNIT
			MIN	TYP‡	MAX	MIN	TYP‡	MAX	
$V_{IH}$	High-level input voltage		2			2			V
$V_{IL}$	Low-level input voltage					0.8			V
$V_{T+} - V_{T-}$	Hysteresis	P or Q inputs	0.4			0.4			V
$V_{IK}$	Input clamp voltage	$V_{CC} = \text{MIN}, I_I = -18 \text{ mA}$	-1.5			-1.5			V
$V_{OH}$	High-level output voltage	$V_{CC} = \text{MIN}, V_{IH} = 2 \text{ V}, V_{IL} = V_{IL\text{max}}, I_{OH} = -400 \mu\text{A}$	2.5			2.7			V
$V_{OL}$	Low-level output voltage	$V_{CC} = \text{MIN}, V_{IH} = 2 \text{ V}, V_{IL} = V_{IL\text{max}}$	$I_{OL} = 12 \text{ mA}$		0.25	0.4	$I_{OL} = 24 \text{ mA}$		V
							0.35	0.5	
$I_I$	Input current at maximum input voltage	Q inputs, 'LS682	$V_{CC} = \text{MAX}, V_I = 5.5 \text{ V}$		0.1			0.1	mA
		All other inputs	$V_{CC} = \text{MAX}, V_I = 7 \text{ V}$						
$I_{IH}$	High-level input current		$V_{CC} = \text{MAX}, V_I = 2.7 \text{ V}$			20			$\mu$ A
$I_{IL}$	Low-level input current	Q inputs, 'LS682	$V_{CC} = \text{MAX}, V_I = 0.4 \text{ V}$		-0.4			-0.4	mA
		All other inputs			-0.2			-0.2	
$I_{OS}^{\S}$	Short-circuit output current	$V_{CC} = \text{MAX}, V_O = 0$	-20	-100	-20	-100			mA
$I_{CC}$	Supply current	'LS682			42	70	42	70	mA
		'LS684			40	65	40	65	
		'LS686			44	75	44	75	
		'LS688			40	65	40	65	

†All typical values are at  $V_{CC} = 5 \text{ V}, T_A = 25^{\circ}\text{C}$ .

§ Not more than one output should be shorted at a time, and duration of the short-circuit should not exceed one second.

NOTE 2:  $I_{CC}$  is measured with any  $\bar{Q}$  inputs grounded, all other inputs at 4.5 V, and all outputs open.

switching characteristics,  $V_{CC} = 5 \text{ V}, T_A = 25^{\circ}\text{C}$

PARAMETER#	FROM (INPUTS)	TO (OUTPUT)	TEST CONDITIONS	'LS682		'LS684		'LS686		'LS688		UNIT
				MIN	TYP	MAX	MIN	TYP	MAX	MIN	TYP	
$t_{PLH}$	P	$\bar{P} = \bar{Q}$	$R_L = 667 \Omega,$ $C_L = 45 \text{ pF},$ All other inputs low, See Note 3	13	25	15	25	13	25	18	27	ns
$t_{PHL}$				15	25	17	25	20	30	20	30	
$t_{PLH}$	Q	$\bar{P} = \bar{Q}$		14	25	16	25	13	25	18	27	ns
$t_{PHL}$				15	25	15	25	21	30	20	30	
$t_{PLH}$	$\bar{G}, \bar{G}1$	$\bar{P} = \bar{Q}$						11	20	12	18	ns
$t_{PHL}$								19	30	13	20	
$t_{PLH}$	P	$\bar{P} > \bar{Q}$		20	30	22	30	19	30			ns
$t_{PHL}$				15	30	17	30	15	30			
$t_{PLH}$	Q	$\bar{P} > \bar{Q}$		21	30	24	30	18	30			ns
$t_{PHL}$				19	30	20	30	19	30			
$t_{PLH}$	$\bar{G}2$	$\bar{P} > \bar{Q}$						21	30			ns
$t_{PHL}$								16	25			

# $t_{PLH}$   $\equiv$  propagation delay time, low-to-high-level outputs;  $t_{PHL}$   $\equiv$  propagation delay time, high-to-low-level output.

NOTE 3: See General Information Section for load circuits and voltage waveforms.

3

TTL DEVICES

**TYPES SN54LS683, SN54LS685, SN54LS687, SN54LS689,  
SN74LS683, SN74LS685, SN74LS687, SN74LS689  
8-BIT MAGNITUDE/IDENTITY COMPARATORS WITH OPEN-COLLECTOR OUTPUTS**

recommended operating conditions 'LS683, 'LS685, 'LS687, 'LS689

	SN54LS'			SN74LS'			UNIT
	MIN	NOM	MAX	MIN	NOM	MAX	
Supply voltage, $V_{CC}$	4.5	5	5.5	4.75	5	5.25	V
High-level output voltage, $V_{OH}$	5.5			5.5			V
Low-level output current, $I_{OL}$	12			24			mA
Operating free-air temperature, $T_A$	-55			125			°C

electrical characteristics over recommended operating free-air temperature range (unless otherwise noted)

PARAMETER		TEST CONDITIONS†	SN54LS'			SN74LS'			UNIT
			MIN	TYP‡	MAX	MIN	TYP‡	MAX	
$V_{IH}$	High-level input voltage		2			2			V
$V_{IL}$	Low-level input voltage		0.7			0.8			V
$V_{T+} - V_{T-}$	Hysteresis	P or Q inputs	0.4			0.4			V
$V_{IK}$	Input clamp voltage	$V_{CC} = \text{MIN}$	-1.5			-1.5			V
$I_{OH}$	High-level output voltage	$V_{CC} = \text{MIN}$ , $V_{IH} = 2 \text{ V}$ , $V_{IL} = V_{IL\text{max}}$ , $V_{OH} = 5.5 \text{ V}$	250			100			$\mu\text{A}$
$V_{OL}$	Low-level output voltage	$V_{CC} = \text{MIN}$ , $V_{IH} = 2 \text{ V}$ , $V_{IL} = V_{IL\text{max}}$	$I_{OL} = 12 \text{ mA}$	0.25	0.4	0.25	0.4	V	
			$I_{OL} = 24 \text{ mA}$			0.35	0.5		
$I_I$	Input current at maximum input voltage	Q inputs, 'LS683	$V_{CC} = \text{MAX}$ , $V_I = 5.5 \text{ V}$			0.1			mA
		All other inputs	$V_{CC} = \text{MAX}$ , $V_I = 7 \text{ V}$						
$I_{IH}$	High-level input current	$V_{CC} = \text{MAX}$ , $V_I = 2.7 \text{ V}$	20			20			$\mu\text{A}$
$I_{IL}$	Low-level input current	Q inputs, 'LS683	$V_{CC} = \text{MAX}$ , $V_I = 0.4 \text{ V}$			-0.4			mA
		All other inputs				-0.2			
$I_{CC}$	Supply current	'LS683	42			70			mA
		'LS685	40			65			
		'LS687	44			75			
		'LS689	40			65			

† For conditions shown as MIN or MAX, use the appropriate value specified under recommended operating conditions.

‡ All typical values are at  $V_{CC} = 5 \text{ V}$ ,  $T_A = 25^\circ\text{C}$ .

NOTE 2:  $I_{CC}$  is measured with any  $\bar{G}$  inputs grounded, all other inputs at 4.5 V, and all outputs open.

switching characteristics,  $V_{CC} = 5 \text{ V}$ ,  $T_A = 25^\circ\text{C}$

PARAMETER¶	FROM (INPUTS)	TO (OUTPUT)	TEST CONDITIONS	'LS683		'LS685		'LS687		'LS689		UNIT
				MIN	TYP	MAX	MIN	TYP	MAX	MIN	TYP	
$t_{PLH}$	P	$\bar{P} = \bar{Q}$	$R_L = 667 \Omega$ , $C_L = 45 \text{ pF}$ , All other inputs low, See Note 3	30	45	30	45	24	35	24	40	ns
$t_{PHL}$				20	30	19	35	20	30	22	35	
$t_{PLH}$	Q	$\bar{P} = \bar{Q}$		24	35	24	45	24	35	24	40	ns
$t_{PHL}$				23	35	23	35	20	30	22	35	
$t_{PLH}$	$\bar{G}, \bar{G}1$	$\bar{P} = \bar{Q}$						21	35	22	35	ns
$t_{PHL}$								18	30	19	30	
$t_{PLH}$	P	$\bar{P} > \bar{Q}$			31	45	32	45	24	35		ns
$t_{PHL}$					17	30	16	35	16	30		
$t_{PLH}$	Q	$\bar{P} > \bar{Q}$			30	45	30	45	24	35		ns
$t_{PHL}$					21	30	20	35	16	30		
$t_{PLH}$	$\bar{G}2$	$\bar{P} > \bar{Q}$						24	35		ns	
$t_{PHL}$								15	30			

¶  $t_{PLH} \equiv$  propagation delay time, low-to-high-level output;  $t_{PHL} \equiv$  propagation delay time, high-to-low-level output.

NOTE 3: See General Information Section for load circuits and voltage waveforms.