

# TYPES SN54LS604 THRU SN54LS607, SN74LS604 THRU SN74LS607 OCTAL 2-INPUT MULTIPLEXED LATCHES

D2545, JULY 1979 — REVISED DECEMBER 1983

(TIM99604 THRU TIM99607)

- Choice of Outputs:  
Three-State ('LS604, 'LS606)  
Open-Collector ('LS605, 'LS607)
- 16 D-Type Registers, One for each Data Input
- Multiplexer Selects Stored Data from Either A Bus or B Bus
- Application Oriented:  
Maximum Speed ('LS604, 'LS605)  
Glitch-Free Operation ('LS606, 'LS607)

SN54LS604 thru SN54LS607 ... JD PACKAGE  
SN74LS604 thru SN74LS607 ... JD OR N PACKAGE  
(TOP VIEW)

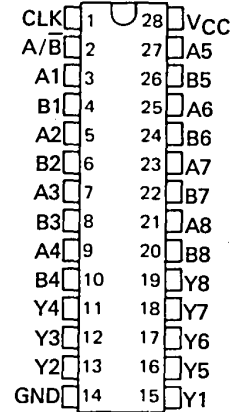

## description

The 'LS604 through 'LS607 multiplexed latches are ideal for storing data from two input buses, A and B, and providing the output bus with stored data from either the A or B register.

The clock loads data on the positive-going (low-level to high-level) transition. The clock pin also controls the active and high-impedance states of the outputs. When the clock pin is low, the outputs are in the high-impedance or off state. When the clock pin is high, the outputs are enabled.

The 'LS604 and 'LS605 are optimized for high-speed operation. The 'LS606 and 'LS607 are especially designed to eliminate decoding voltage spikes.

These functions are ideal for interface from a 16-bit microprocessor to a 64K RAM board. The row and column addresses can be loaded as one word from the microprocessor and then multiplexed sequentially to the RAM during the time that RAS and CAS are active.

SN54LS604 thru SN54LS607 ... FK PACKAGE  
SN74LS604 thru SN74LS607 ... FN PACKAGE  
(TOP VIEW)

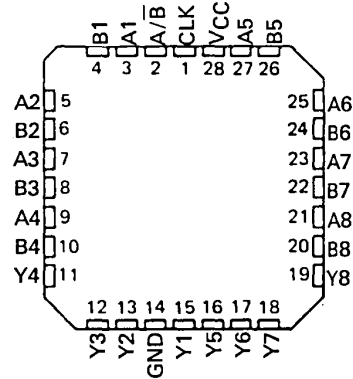

The SN54LS604 through SN54LS607 are characterized for operation over the full military temperature range of  $-55^{\circ}\text{C}$  to  $125^{\circ}\text{C}$ ; the SN74LS604 through SN74LS607 are characterized for operation from  $0^{\circ}\text{C}$  to  $70^{\circ}\text{C}$ .

FUNCTION TABLE

INPUTS				OUTPUTS
A1-A8	B1-B8	SELECT A/B	CLOCK	Y1-Y8
A data	B data	L	↑	B data
A data	B data	H	↑	A data
X	X	X	L	Z or Off
X	X	L	H	B register stored data
X	X	H	H	A register stored data

H = high level (steady state)

L = low level (steady state)

X = irrelevant

Z = high-impedance state

Off = H if pull-up resistor is connected to open-collector output

↑ = transition from low to high level

**PRODUCTION DATA**  
This document contains information current as of publication date. Products conform to specifications per the terms of Texas Instruments standard warranty. Production processing does not necessarily include testing of all parameters.

**TEXAS INSTRUMENTS**  
POST OFFICE BOX 225012 • DALLAS, TEXAS 75265



TTL DEVICES

# TYPES SN54LS604 THRU SN54LS607, SN74LS604 THRU SN74LS607 OCTAL 2-INPUT MULTIPLEXED LATCHES

## schematics of inputs and outputs

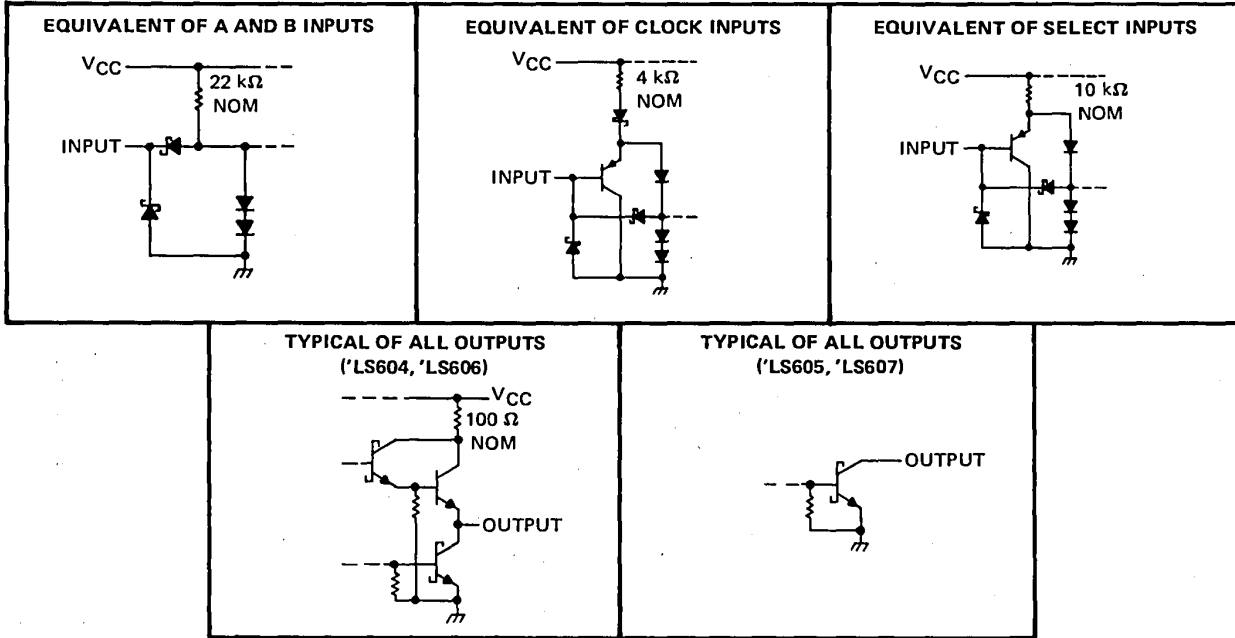

3

## logic symbols

TTL DEVICES

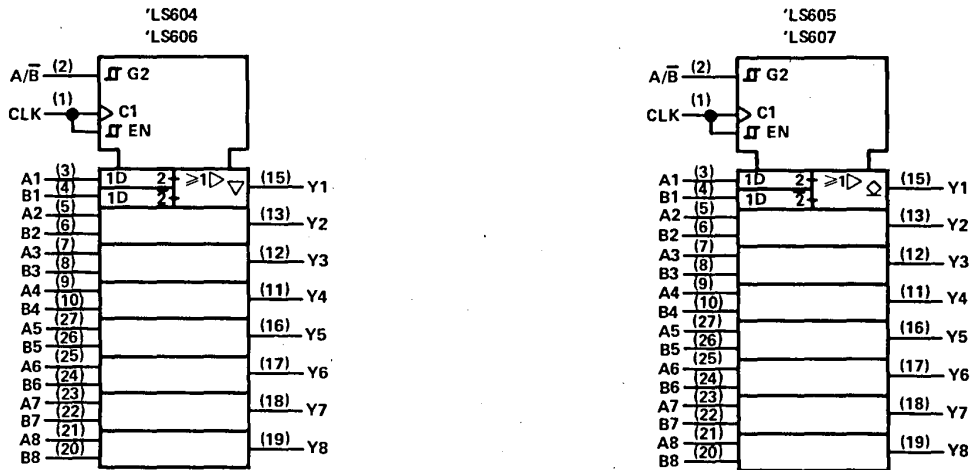

Pin numbers shown on logic notation are for JD or N packages.

TYPES SN54LS604 THRU SN54LS607, SN74LS604 THRU SN74LS607  
OCTAL 2-INPUT MULTIPLEXED LATCHES

logic diagram (positive logic)

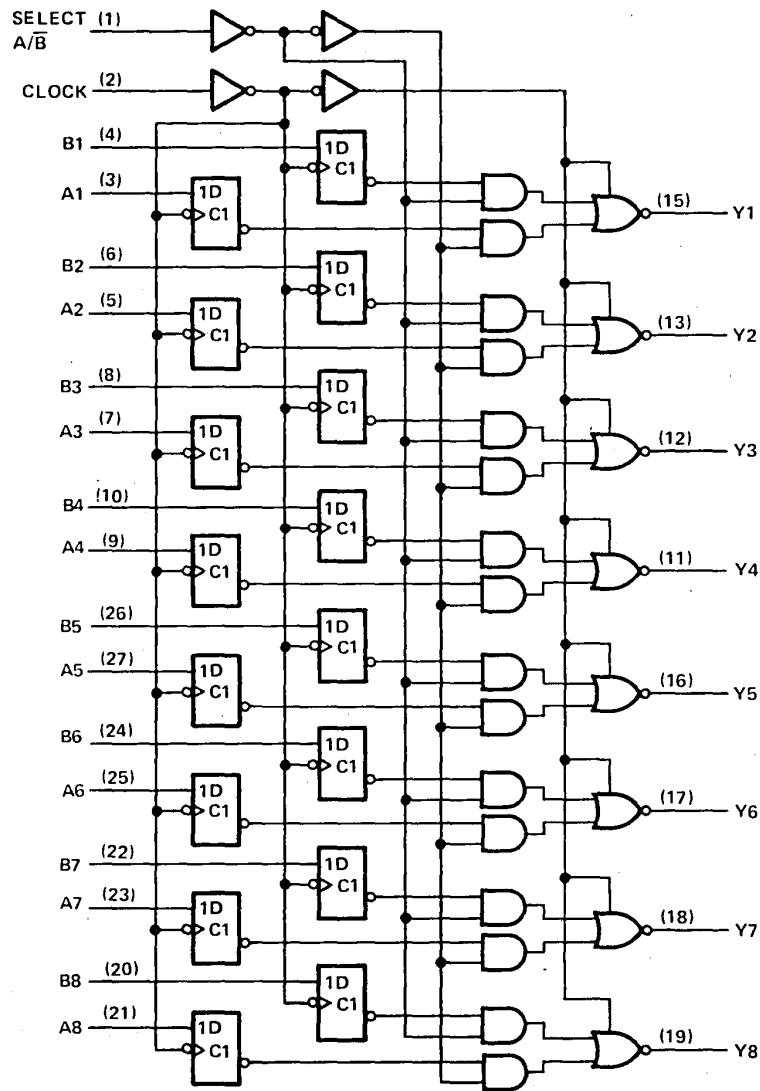

# TYPES SN54LS604, SN54LS606, SN74LS604, SN74LS606

## OCTAL 2-INPUT MULTIPLEXED LATCHES WITH 3-STATE OUTPUTS

### recommended operating conditions

	SN54LS604 SN54LS606			SN74LS604 SN74LS606			UNIT
	MIN	NOM	MAX	MIN	NOM	MAX	
Supply voltage, $V_{CC}$ (see Note 1)	4.5	5	5.5	4.75	5	5.25	V
High-level output current, $I_{OH}$			-1			-2.6	mA
Low-level output current, $I_{OL}$			12			24	mA
Width of clock pulse, $t_w$	20			20			ns
Setup time, $t_{su}$	20†			20†			ns
Hold time, $t_h$	0†			0†			ns
Operating free-air temperature, $T_A$	-55		125	0		70	°C

NOTE 1: Voltage values are with respect to network ground terminal.

### electrical characteristics over recommended operating free-air temperature range (unless otherwise noted)

PARAMETER	TEST CONDITIONS†	SN54LS604 SN54LS606			SN74LS604 SN74LS606			UNIT
		MIN	TYP‡	MAX	MIN	TYP‡	MAX	
$V_{IH}$ High-level input voltage		2			2			V
$V_{IL}$ Low-level input voltage				0.7			0.8	V
$V_{IK}$ Input clamp voltage	$V_{CC} = \text{MIN}, I_I = -18 \text{ mA}$			-1.5			-1.5	V
$V_{OH}$ High-level output voltage	$V_{CC} = \text{MIN}, V_{IH} = 2 \text{ V}, V_{IL} = V_{IL \text{ max}}, I_{OH} = \text{MAX}$	2.4	3.1		2.4	3.1		V
$V_{OL}$ Low-level output voltage	$V_{CC} = \text{MIN}, V_{IH} = 2 \text{ V}, V_{IL} = V_{IL \text{ max}}, I_{OL} = 12 \text{ mA}$		0.25	0.4		0.25	0.4	V
$I_{OZH}$ Off-state output current, high-level voltage applied	$V_{CC} = \text{MAX}, V_{IH} = 2 \text{ V}, V_{IL} = V_{IL \text{ max}}, V_O = 2.7 \text{ V}$			20			20	µA
$I_{OZL}$ Off-state output current, low-level voltage applied	$V_{CC} = \text{MAX}, V_{IH} = 2 \text{ V}, V_{IL} = V_{IL \text{ max}}, V_O = 0.4$			-20			-20	µA
$I_I$ Input current at maximum input voltage	$V_{CC} = \text{MAX}, V_I = 7 \text{ V}$			0.1			0.1	mA
$I_{IH}$ High-level input current	$V_{CC} = \text{MAX}, V_I = 2.7 \text{ V}$	A, B		20			20	µA
		CLK, SELECT		20			20	µA
$I_{IL}$ Low-level input current	$V_{CC} = \text{MAX}, V_I = 0.4 \text{ V}$	A, B		-0.4			-0.4	mA
		CLK, SELECT		-0.2			-0.2	mA
$I_{OS}$ Short-circuit output current §	$V_{CC} = \text{MAX}$	-30		-130	-30		-130	mA
$I_{CC}$ Supply current	$V_{CC} = \text{MAX},$ See Note 2		55	70		55	70	mA

† For conditions shown as MIN or MAX, use the appropriate value specified under recommended operating conditions.

‡ All typical values are at  $V_{CC} = 5 \text{ V}, T_A = 25^\circ \text{C}$ .

§ Note more than one output should be shorted at a time, and duration of the short-circuit should not exceed one second.

NOTE 2:  $I_{CC}$  is tested with all inputs grounded and all outputs open.

### switching characteristics, $V_{CC} = 5 \text{ V}, T_A = 25^\circ \text{C}$

PARAMETER	FROM (INPUT)	TEST CONDITIONS	'LS604			'LS606			UNIT
			MIN	TYP	MAX	MIN	TYP	MAX	
$t_{PLH}$	Select A/B (Data: A = H, B = L)	$C_L = 45 \text{ pF}, R_L = 667 \Omega,$ See Note 3		15	25		36	50	ns
$t_{PHL}$				23	35		16	30	
$t_{PLH}$	Select A/B (Data: A = L, B = H)			31	45		22	35	ns
$t_{PHL}$				19	30		22	35	
$t_{PZH}$	Clock				19	30		27	40
$t_{PZL}$				28	40		35	50	
$t_{PHZ}$	Clock	$C_L = 5 \text{ pF}, R_L = 667 \Omega,$ See Note 3		20	30		20	30	ns
$t_{PLZ}$					15	25		15	

$t_{PLH}$  ≡ propagation delay time, low-to-high-level output

$t_{PHL}$  ≡ propagation delay time, high-to-low-level output

$t_{PZH}$  ≡ output enable time to high level

$t_{PZL}$  ≡ output enable time to low level

$t_{PHZ}$  ≡ output disable time from high level

$t_{PLZ}$  ≡ output disable time from low level

NOTE 3: See General Information Section for load circuits and voltage waveforms.

## TYPES SN54LS605, SN54LS607, SN74LS605, SN74LS607 OCTAL 2-INPUT MULTIPLEXED LATCHES WITH OPEN-COLLECTOR OUTPUTS

### recommended operating conditions

	SN54LS605 SN54LS607			SN74LS605 SN74LS607			UNIT
	MIN	NOM	MAX	MIN	NOM	MAX	
Supply voltage, $V_{CC}$ (see Note 1)	4.5	5	5.5	4.75	5	5.25	V
High-level output voltage, $V_{OH}$			5.5			5.5	V
Low-level output current, $I_{OL}$			12			24	mA
Width of clock pulse, $t_w$	20			20			ns
Setup time, $t_{su}$	20†			20†			ns
Hold time, $t_h$	0†			0†			ns
Operating free-air temperature, $T_A$	-55		125	0		70	°C

NOTE 1: Voltage values are with respect to network ground terminal.

### electrical characteristics over recommended operating free-air temperature range (unless otherwise noted)

PARAMETER	TEST CONDITIONS†	SN54LS605 SN54LS607			SN74LS605 SN74LS607			UNIT	
		MIN	TYP‡	MAX	MIN	TYP‡	MAX		
$V_{IH}$ High-level input voltage		2			2			V	
$V_{IL}$ Low-level input voltage				0.7			0.8	V	
$V_{IK}$ Input clamp voltage	$V_{CC} = \text{MIN}, I_I = -18 \text{ mA}$			-1.5			-1.5	V	
$I_{OH}$ High-level output current	$V_{CC} = \text{MIN}, V_{IH} = 2 \text{ V}, V_{IL} = V_{IL \text{ max}}, V_{OH} = 5.5 \text{ V}$			250			250	μA	
$V_{OL}$ Low-level output voltage	$V_{CC} = \text{MIN}, V_{IH} = 2 \text{ V}, V_{IL} = V_{IL \text{ max}}$			0.25	0.4		0.25	0.4	V
							0.35	0.5	
$I_I$ Input current at maximum input voltage	$V_{CC} = \text{MAX}, V_I = 7 \text{ V}$			0.1			0.1	mA	
				0.1			0.1		
$I_{IH}$ High-level input current	$V_{CC} = \text{MAX}, V_I = 2.7 \text{ V}$			20			20	μA	
				20			20		
$I_{IL}$ Low-level input current	$V_{CC} = \text{MAX}, V_I = 0.4 \text{ V}$			-0.4			-0.4	mA	
				-0.2			-0.2		
$I_{CC}$ Supply current	$V_{CC} = \text{MAX},$ See Note 2			40	60		40	60	mA

†For conditions shown as MIN or MAX, use the appropriate value specified under recommended operating conditions.

‡All typical values are at  $V_{CC} = 5 \text{ V}, T_A = 25^\circ\text{C}$ .

NOTE 2:  $I_{CC}$  is tested with all inputs grounded and all outputs open.

### switching characteristics, $V_{CC} = 5 \text{ V}, T_A = 25^\circ\text{C}$

PARAMETER	FROM (INPUT)	TEST CONDITIONS	'LS605			'LS607			UNIT
			MIN	TYP	MAX	MIN	TYP	MAX	
$t_{PLH}$	Select $A/\bar{B}$	$C_L = 45 \text{ pF}, R_L = 667 \Omega,$ See Note 3		28	40		51	70	ns
$t_{PHL}$	(Data: $A = H, B = L$ )			28	40		21	30	
$t_{PLH}$	Select $A/\bar{B}$			39	60		28	40	ns
$t_{PHL}$	(Data: $A = L, B = H$ )			25	40		28	40	
$t_{PLH}$	Clock			27	40		30	45	ns
$t_{PHL}$				25	40		32	45	

$t_{PLH}$  ≡ propagation delay time, low-to-high-level output

$t_{PHL}$  ≡ propagation delay time, high-to-low-level output

NOTE 3: See General Information Section for load circuits and voltage waveforms.

3

TTL DEVICES